

# Frequency Combs

Compact, robust, high-end ... and convenient

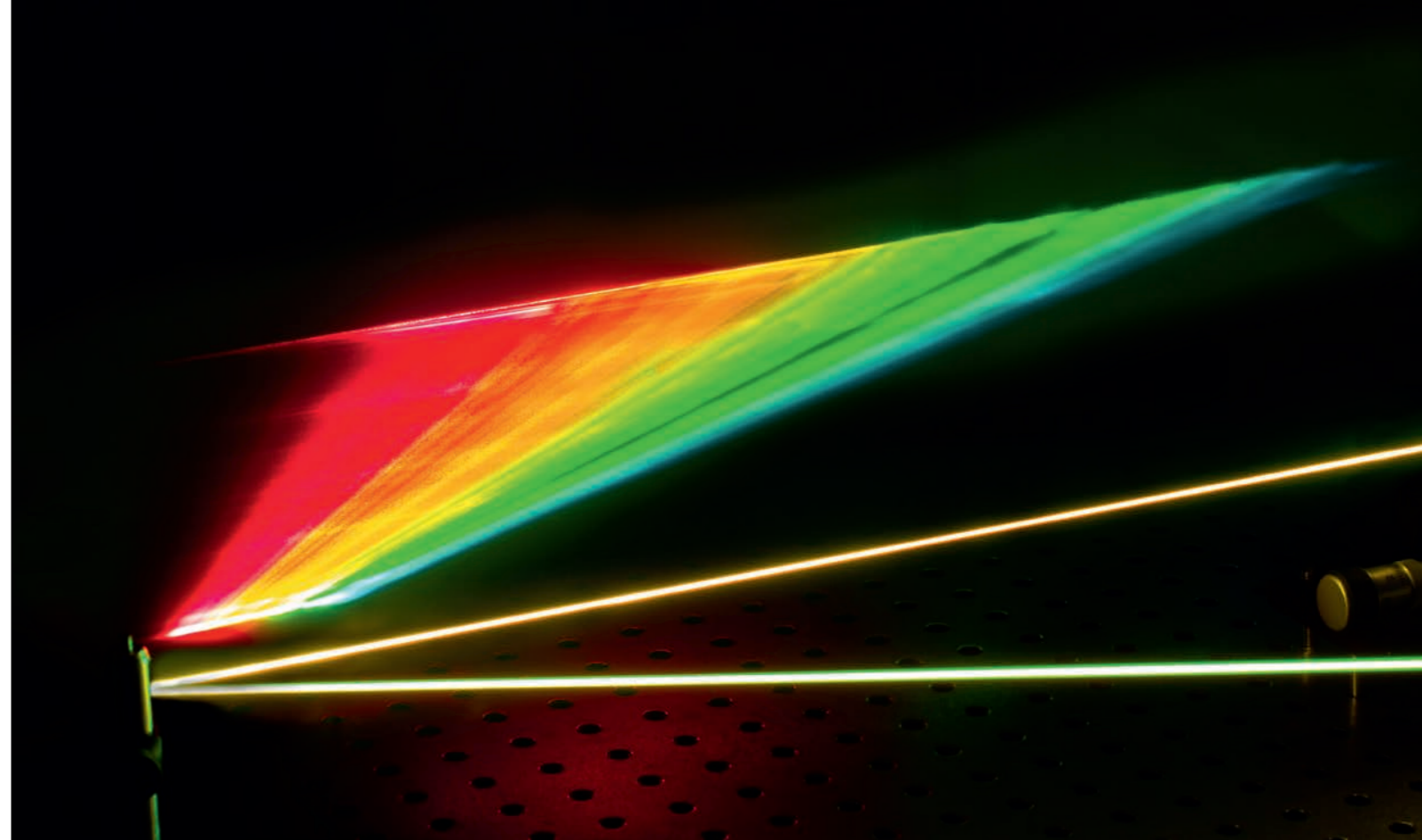

- Laser Reference
- High-resolution Spectroscopy
- Optical Clocks
- Microwave Generation
- Dual-comb Spectroscopy
- Direct Frequency Comb Spectroscopy
- Interferometry
- Transportable AMO Systems
- Quantum Computing

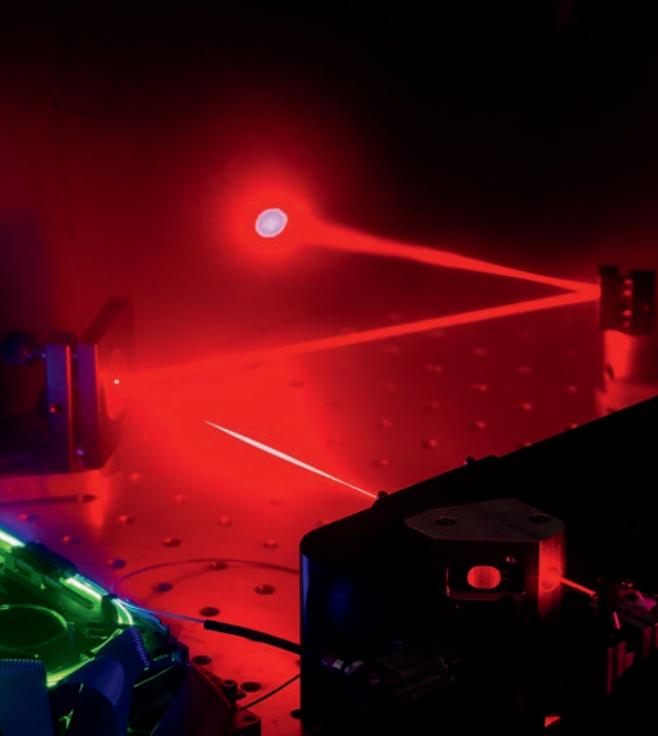

## Contents

|   |    |
|---|----|
| <b>Introduction</b> .....                             | 3  |
| <b>All components overview</b> .....                  | 4  |
| <br>  |    |
| <b>DFC CORE +</b> .....                               | 6  |
| Compact high-performance frequency comb               |    |
| <br>  |    |
| <b>DFC EXT</b> .....                                  | 10 |
| Wavelength conversion from 1560 nm to 420 - 2000 nm   |    |
| <br>  |    |
| <b>DFC BC / DFC BCF / DFC MD</b> .....                | 11 |
| Flexible beat detection units                         |    |
| <br>  |    |
| <b>FALC &amp; PFD</b> .....                           | 12 |
| Locking electronics: Push-button phase-frequency lock |    |
| <br>  |    |
| <b>TOPAS DFC</b> .....                                | 13 |
| Convenient user interface (GUI)                       |    |
| <br>  |    |
| <b>Complete DFC system</b> .....                      | 14 |
| Buy a stable, optical frequency                       |    |
| <br>  |    |
| <b>Example scheme of complete DFC System</b> .....    | 15 |
| For strontium lattice clock experiment                |    |

# Difference Frequency Comb (DFC)

## Compact, robust, high-end ... and convenient

TOPTICA's Difference Frequency Comb (DFC) is a compact, robust, high-end resolution featuring turn-key operation in a 19 inch format. All driving and locking electronics for RF references are integrated into the robust 19-inch housing of the Erbium fiber based frequency comb DFC CORE +. It features 4 or optionally 8 intrinsically offset-free outputs at 1560 nm which can be equipped with wavelength extension modules (DFC EXT) converting the comb light to any wavelength between 420 nm and 2000 nm.

The convenient user interface offers time-saving remote control of the frequency comb laser system and all its accessories like counter, spectrum analyzer or wavelength meter from a single interface. It features an automatic lock to RF references, remote locking to optical references and remote locking of TOPTICA cw-lasers to the DFC.

The patented CERO ("zero-  $f_{\text{CEO}}$ ") technology uses difference frequency generation for a passive, all-optical phase-lock of  $f_{\text{CEO}}$ . This simple and reliable technology offers intrinsic stability and an effective  $f_{\text{CEO}}$  locking bandwidth as high as the repetition rate of the frequency comb. Advantages of the CERO technology are ultra-low  $f_{\text{CEO}}$  phase noise and a narrow free running linewidth.

The DFC profits from TOPTICA's 20 years of experience building high-quality scientific and industry-grade lasers. It can be combined with any TOPTICA's world famous cw-lasers and locking electronics to become a complete laser system ready to use from day one after installation.

With its intrinsic stability and ease of use the DFC is the number one choice for anyone looking for high-end performance combined with a high level of robustness.

### Applications

- Laser Reference
- High-resolution Spectroscopy
- Optical Clocks
- Microwave Generation
- Dual-comb Spectroscopy
- Direct Frequency Comb Spectroscopy
- Interferometry
- Transportable AMO Systems
- Quantum Computing

# Difference Frequency Comb (DFC)

All components overview



## 01 DFC CORE +

- Frequency comb with CERO technology
- 4 offset-free outputs @ 1560 nm
- All electronics included

## 02 DFC EXT

- Housing for up to 3 wavelength extensions
- Outputs between 420 - 2000 nm

## 03 DFC MD

- Monochromatic detector
- Grating-based adjustable filter
- Low-noise photodetector

## 04 DFC BC

- Beam combiner
- Adjustable split ratio
- Pure cw-light output
- Adjustable power ratio

## 05 Locking electronics

- FALC - Fast PID controller
- PFD - Phase-Frequency Detector
- DLC EXT housing

## 06 DLC DL pro

- Or any TOPTICA Laser
- (420 - 2000 nm)

## 07 Complete DFC Systems

- Complete stabilized laser systems
- Rack mounted or table top
- Including DFC CORE +, DFC EXT, DFC BC/MD, FALC & PFD, cw-laser, HighFinesse wavelength meter, counter, spectrum analyzer



The DFC CORE + is a robust, 19 inch compatible optical frequency comb. It is the core system for applications like optical clocks, microwave generation or phase-locking of cw-lasers and can be equipped with additional options (page 14) and wavelength extensions (page 10). Its unique  $f_{\text{CEO}}$ -stabilization is based on Difference Frequency Generation (DFG) and comes with many advantages such as high robustness and ultra-low phase noise. The DFC CORE + features an outstanding stability and accuracy which is suitable for use with the best optical clocks. More than 20 years of engineering experience building high-quality scientific and industry-grade lasers went into its design, it's a TOPTICA laser.

**Outstanding specifications**

- Comb spacing: 200 MHz
- Stability:  $8 \cdot 10^{-18}$  in 1 s\*,  $5 \cdot 10^{-20}$  in 1000 s\*
- Accuracy:  $1 \cdot 10^{-18}$  for  $\tau > 100$  s\*
- Integrated phase noise  $f_{\text{CEO}}$ :  $< 65$  mrad [70 MHz - 20 MHz]
- Linewidth:  $< 1$  Hz (locked to optical reference)  
20 kHz free running
- Compact dimension: 133 x 450 x 633 mm<sup>3</sup>, incl. electronics
- Turn-key, full remote control

\* Phase-locked to optical reference

**Advantages of  $f_{\text{CEO}}$ -stabilization by Difference Frequency Generation (DFG)**

- Effective  $f_{\text{CEO}}$ -locking bandwidth = 200 MHz (repetition rate)
- $f_n = n f_{\text{rep}}$ , perfect for use with optical reference  
Puppe et al., Opt. Lett. **41**, 8 (2016)
- Narrow free running linewidth
- Intrinsically stable
- Simple and reliable
- Passive, all-optical phase-lock

**CERO PRINCIPLE:  $f_{\text{CEO}}$ -stabilization by Difference Frequency Generation (DFG)**

**CERO: Inherently noise-free**

TOPTICA's unique difference frequency comb DFC implements the completely passive CERO ("zero- $f_{\text{CEO}}$ ") technology, which inherently stabilizes  $f_{\text{CEO}}$  and the carrier envelope phase.

The DFC is the first commercial system based on this superior patented technology (patent number: DE102004022037). The fiber-based comb combines the convenience and robustness of fiber lasers with low-noise performance.

The CERO principle is described in the following sketch.

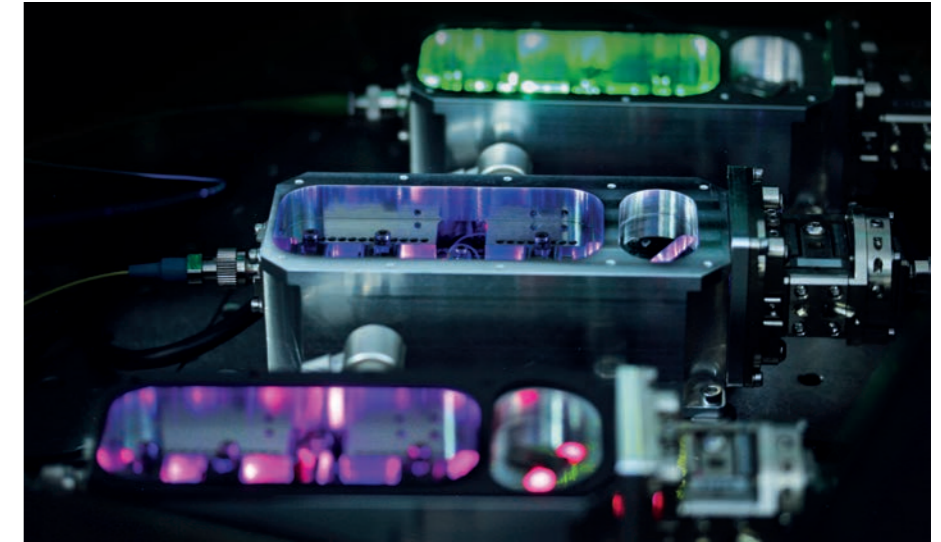

Low-noise Er-fiber oscillator @ 1560 nm

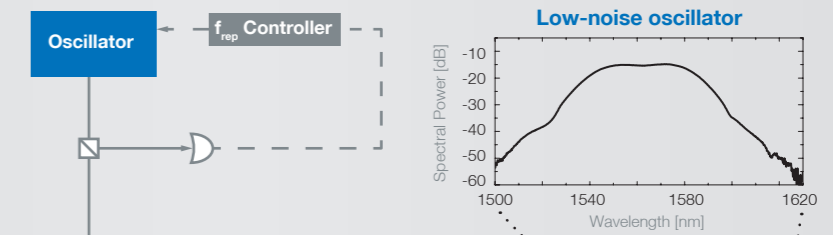

Supercontinuum spanning 193 THz ( $\pm 1560$  nm).

Blue shaded frequencies have identical  $f_{\text{CEO}}$ .

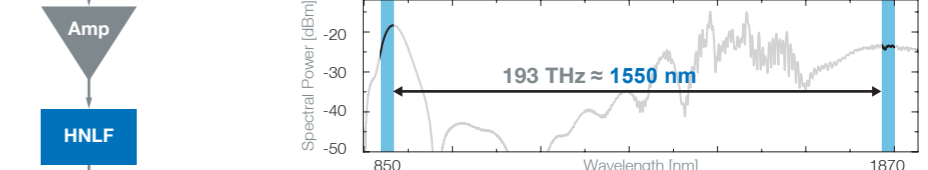

$$= (m f_{\text{rep}} + f_{\text{CEO}}) - (l f_{\text{rep}} + f_{\text{CEO}}) = (c/850 \text{ nm} + f_{\text{CEO}}) - (c/1870 \text{ nm} + f_{\text{CEO}}) = c/1560 \text{ nm}$$

- DFG between blue shaded frequencies in nonlinear crystal
- Resulting comb @ 1560 nm is:  $f_{\text{CEO}}$  stabilized, CEP stabilized
- $f_{\text{CEO}}$  is fixed to zero
- $f_{\text{CEO}}$  and  $f_{\text{rep}}$  are completely decoupled
- New comb equation:  $f_n = f_{\text{CEO}} + n \cdot f_{\text{rep}}$

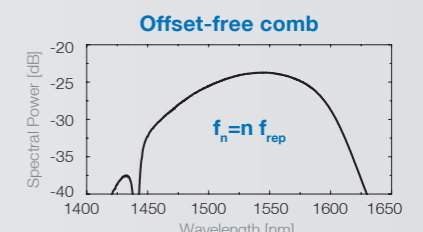
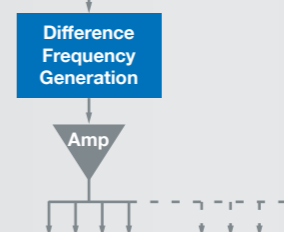

# DFC CORE +

## Compact high-performance frequency comb

 DANGER – VISIBLE AND INVISIBLE LASER RADIATION  
AVOID EYE OR SKIN EXPOSURE TO DIRECT OR  
SCATTERED RADIATION  
CLASS 4 LASER PRODUCT, EN60825-1:2014



### Compact

Fully self-referenced comb including electronics –  
Rack-mount ready

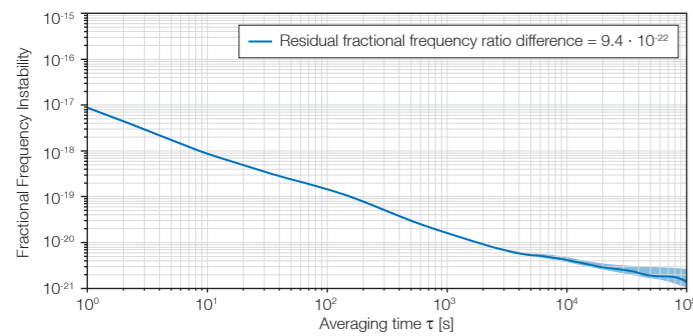

### High-end

Stability transfer at the  $10^{-21}$  level  
Benkler et al., Optics Express [27], 36886 (2019)



### Robust

And it stays in lock ... !  
48 hours in the life of a DFC



### Convenient

Control everything from a single window



| Specifications                   | DFC CORE +  |   |
|----------------------------------|---|---|
| Center wavelength                | 1560 nm (other wavelengths see page 10)   |   |
| Comb spacing                     | 200 or 80 MHz   |   |
| Laser outputs                    | 4 or 8, fiber coupled, polarization maintaining, FC/APC   |   |
| Bandwidth                        | > 20 nm, each output  |   |
| Power                            | > 10 mW, each output  |   |
| Integrated phase noise $f_{CEO}$ | < 40 mrad [100 Hz - 2 MHz], < 65 mrad [70 mHz - 20 MHz]   |   |
| Linewidth                        | < 1 Hz *  |   |
| Loop bandwidth $f_{rep\_lock}$   | > 400 kHz (typ. 450 kHz)*   | 10 kHz, optimal with DFC RF             |
| Stability                        | $8 \cdot 10^{-18}$ in 1s*, $5 \cdot 10^{-20}$ in 1000 s*  | $1 \cdot 10^{-13}$ in 1 s**             |
| Accuracy                         | $1 \cdot 10^{-18}$ for $\tau > 100$ s*  | $1 \cdot 10^{-14}$ for $\tau > 100$ s** |
| Bandwidth piezo $f_{rep}$        | > 50 kHz  |   |
| Reference                        | Optical reference*** or DFC RF***, Low-noise oven-controlled quartz (OCXO)  |   |
| Reference input                  | <ul style="list-style-type: none"> <li>· 800 MHz for RF reference</li> <li>· 10 MHz with DFC RF</li> <li>· High bandwidth <math>I_{mod}</math> (DC - 10 MHz) for optical reference</li> </ul> |   |
| Dimensions (H x W x D)           | 133 x 450 x 633 mm <sup>3</sup> , incl. electronics   |   |
| Cooling requirements             | Air cooled  |   |
| Power consumption                | < 110 W   |   |
| Operating temperature            | $21 \pm 4$ °C   |   |
| Weight                           | < 32 kg   |   |
| Power supply                     | Mains connection: 100 .. 240 V~, 50/60 Hz, 4.0 A, Power adaptor output: 220 W, 24 V/9.2 A   |   |
| Control computer                 | Laptop, Windows 10, English   |   |

\* Phase-locked to optical reference, \*\* Phase-locked to RF reference, \*\*\* not included

### DFC CORE +

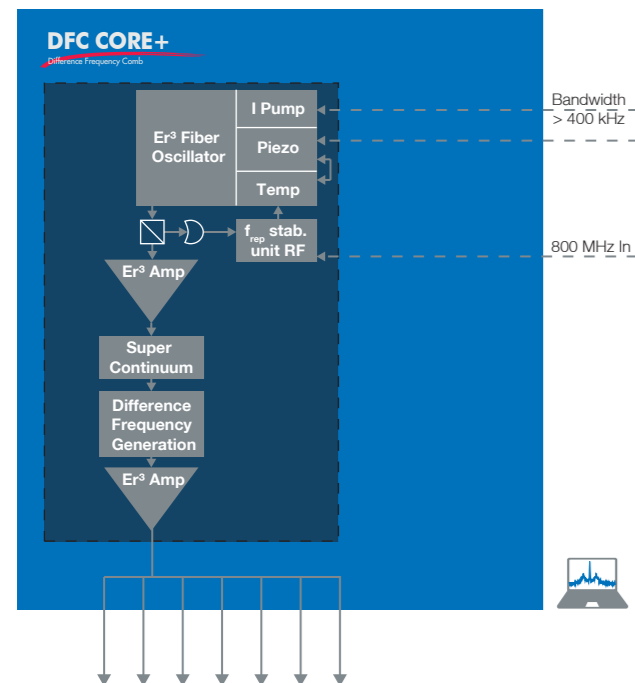

### DFC CORE + includes

- Laser head based on CERO technology
- Robust aluminum housing, 19 inch format, vibration damped optical units
- Driving and RF locking electronics included in 19 inch housing
- Low-noise all PM-fiber oscillator
- Erbium-doped fiber amplifier + HNLF for supercontinuum generation
- DFG unit with CERO technology
- Erbium-doped fiber distribution amplifier
- 4 or optionally 8 offset-free outputs @ 1560 nm

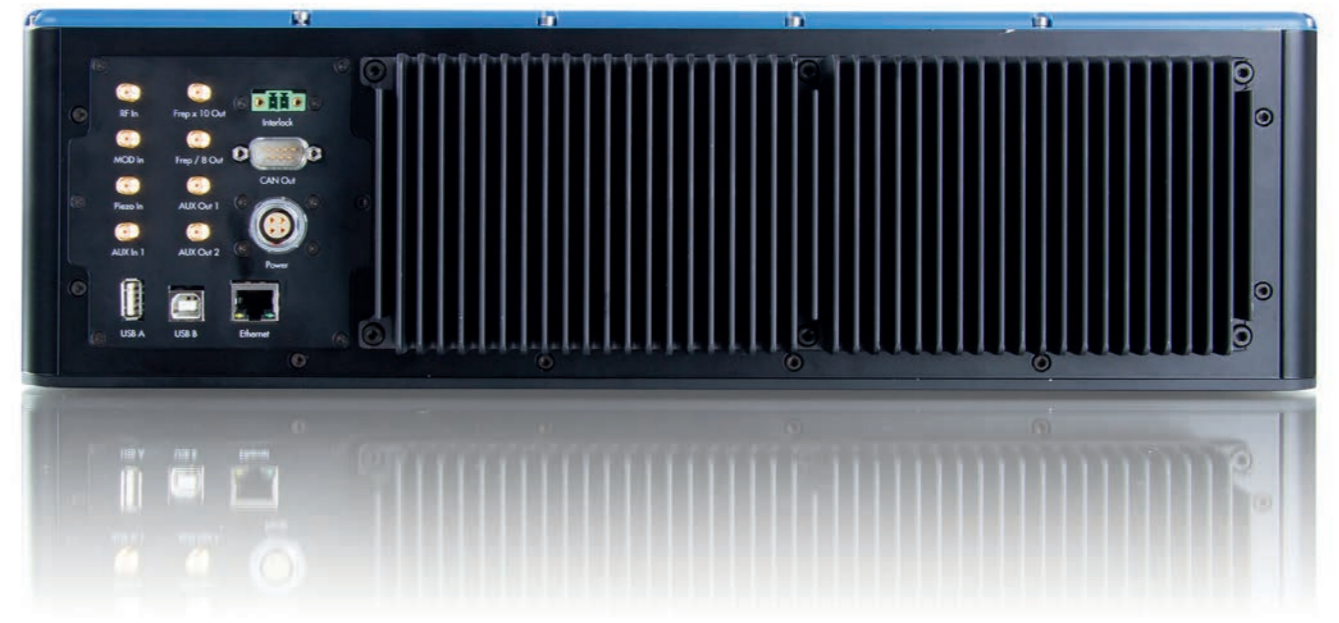

# DFC EXT

Wavelength conversion from 1560 nm to 420 - 2000 nm

# DFC BC / DFC BCF / DFC MD

Flexible beat detection units

## Key Features

- Modular extensions
- For use with DFC CORE +
- Independent remote control of different extensions
- Up to three extensions per DFC EXT
- Custom extensions and beat detection in DFC EXT housing, e.g. single branch dual wavelength



| Model      | Description   |
|------------|---|
| DFC EXT    | Housing for Wavelength Extensions   |
| DFC IR     | Centered @ 1560 nm, bandwidth > 80 nm, typ. 100 nm  |
| DFC NIR    | Centered @ 780 nm, bandwidth > 35 nm, typ. 40 nm  |
| DFC DVIS*  | Wavelength range 420 ( $f_{rep} = 80$ MHz), 450 ( $f_{rep} = 200$ MHz) - 860 nm, bandwidth typ. 5 nm @ 698 nm, typ. 1 nm @ 420 nm |
| DFC SCNIR* | Wavelength range 840 nm ( $f_{rep} = 80$ MHz), 860 nm ( $f_{rep} = 200$ MHz) - 980 nm, bandwidth > 50 nm, typ. 100 nm @ 935 nm    |
| DFC SCIR*  | Wavelength range 980 - 2000, bandwidth > 150 nm   |

Other extensions on request, \* tunable (patent protected, US 8284808B2), please inquire for more details

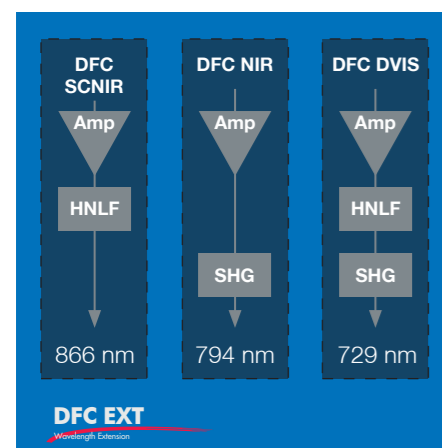

DFC EXT with DFC SCNIR, DFC NIR and DFC DVIS

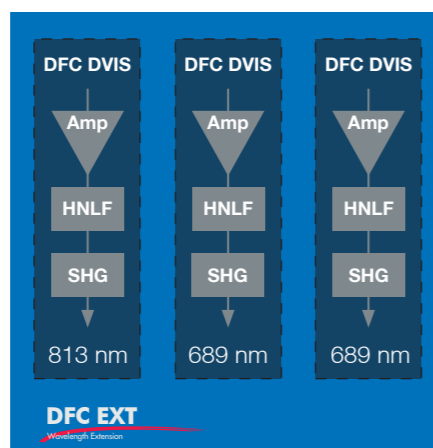

DFC EXT with 3 DFC DVIS

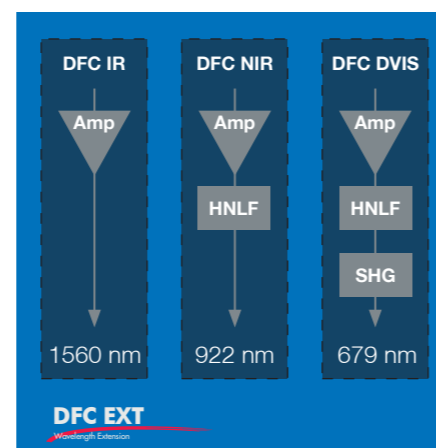

DFC EXT with DFC IR, DFC NIR and DFC DVIS



## DFC BC

- DFC + cw-laser beam combiner
- Free-space optics, fiber FC/APC fiber coupled
- Available from 420 to 2000 nm
- Adjustable power ratio comb vs. cw
- Comb-free cw output for experiment
- Adjustable split ratio for cw laser
- Wavelength range > 50 nm (depends on central wavelength)
- To be used in combination with DFC MD for beat detection (SM/PM fiber included)
- Dimensions (HxWxD): 49 x 100 x 100 mm<sup>3</sup>

## DFC BCF

- DFC + cw-laser fiber beam combiner
- Available wavelengths 980 nm, 1030 nm, 1300 nm, 1550 nm (other wavelengths on request)
- Fixed power ratio comb vs. cw
- To be used in combination with DFC MD for beat detection
- Dimensions (HxWxD): 23 x 90 x 200 mm<sup>3</sup>

## DFC MD

- Grating based tunable filter, 10 GHz bandwidth, < 1 GHz resolution
- Low-noise photo diode for beat detection
- Available from 420 to 2000 nm
- RF output suitable as direct input for TOPTICA locking electronics
- Stand-alone narrow band frequency filter
- Wavelength range 50 nm (depends on central wavelength)
- Dimensions (HxWxD): 64 x 60 x 120 mm<sup>3</sup>



Designed for use with DFC and DL pro.

**Key Features**

- Robust phase and frequency lock
- Up to 45 MHz bandwidth
- Remote control and locking
- Convenient software interface integrated into DFC GUI (TOPAS DFC)
- Tunable RF source for offset phase-frequency lock
- 10 MHz reference input
- Beat signal conditioning for beat detection and frequency counting



**Key Features**

- Central GUI for all DFC modules
- One interface for all system configurations
- Remote control
- Remote locking
- Beat monitoring with cw lock status
- Frequency measurement of cw-laser
- Automatic data acquisition and data analysis
- For up to 8 lasers simultaneously

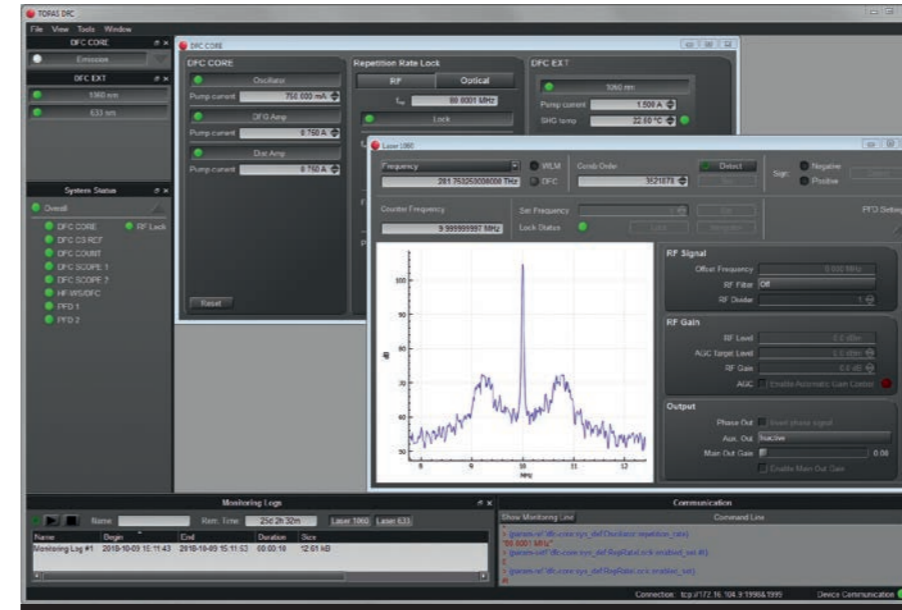

|   | PFD                             | FALC110                   | DLC pro Lock                          | DFC CORE + internal Lock   |
|---|---------------------------------|---------------------------|---------------------------------------|----------------------------|
| Description                                   | Phase Frequency Detector        | Fast Analog PID           | All-digital PID                       | All-digital PID            |
| Recommended for lock of DL pro to DFC         | ✓                               | ✓                         | ✓                                     |                            |
| Recommended for lock of DFC to opt. reference | ✓                               | ✓                         |                                       | ✓                          |
| Task  | Error signal generation         | High bandwidth phase-lock | Slow feedback to DLC pro laser        | Slow feedback to DFC       |
| Max. bandwidth                                |                                 | ≈ 45 MHz                  | ≈ 30 kHz                              | ≈ 30 kHz                   |
| Remote control                                | ✓                               | via PFD                   | ✓                                     | ✓                          |
| Rack compatibility                            | ✓                               | ✓                         | ✓                                     | ✓                          |
| Stand-alone                                   | ✓                               | ✓                         | optional software license for DLC pro | included in any DFC CORE + |
| Power supply                                  | DLC Ext                         | DLC Ext                   |                                       |                            |
| Dimensions PFD, FALC110, DLC EXT              | 131 x 184 x 286 mm <sup>3</sup> |                           |                                       |                            |

**Example: Phase frequency lock of DLC DL pro to DFC**

The DFC locking electronics consisting of the Phase Frequency Detector (PFD) and FALC 110 provides high-end phase frequency locking for comb applications. The PFD RF input is designed for use with the RF output signal of the DFC MD. The error signal generated by the PFD is fed to the input of the FALC 110 regulator. The main output of the FALC is passed through the PFD to allow for remote switching of the fast feedback loop which modulates the laser diode current. A copy of the error signal (mon. out) is used to close the slow feedback loop acting on the DL pro piezo (Fine In) with the all-digital PID of the DLC pro.

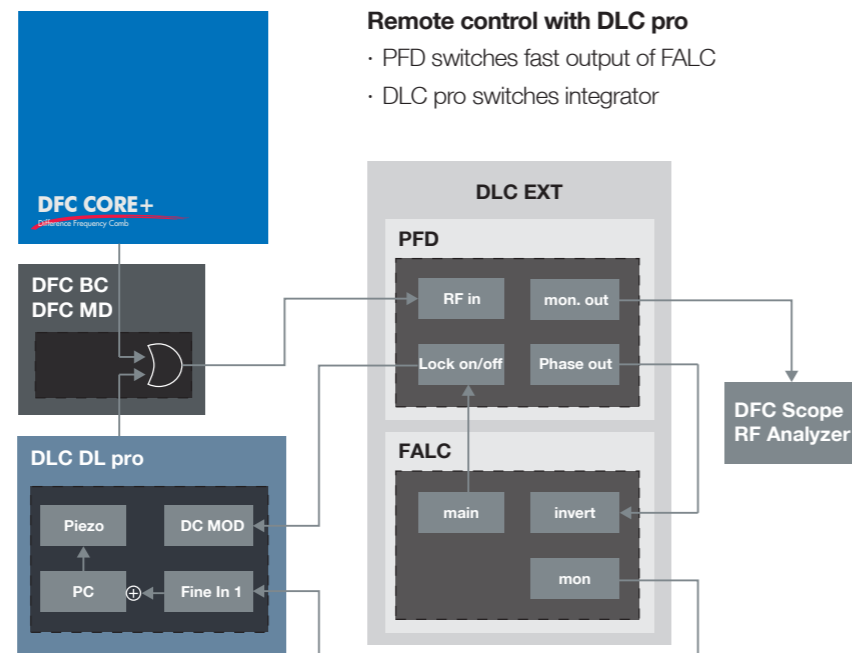

**Remote control with DLC pro**

- PFD switches fast output of FALC
- DLC pro switches integrator

| System version             | 1.0        | 1.1                   | 2.1   | 2.2   | 3.1   | 3.2   | 4.1   | 4.2   |
|----------------------------|------------|-----------------------|---|---|---|---|---|---|
| <b>System components</b>   | DFC CORE + | DFC CORE + FALC & PFD | DFC CORE + FALC & PFD<br>DFC SCOPE<br>DFC COUNT | DFC CORE + FALC & PFD<br>DFC SCOPE<br>DFC COUNT<br>WS8-30 | DFC CORE + FALC & PFD<br>DFC SCOPE<br>DFC COUNT | DFC CORE + FALC & PFD<br>DFC SCOPE<br>DFC COUNT<br>WS8-30 | DFC CORE + FALC & PFD<br>DFC SCOPE<br>DFC COUNT<br>DLC DL pro<br>FALC & PFD | DFC CORE + FALC & PFD<br>DFC SCOPE<br>DFC COUNT<br>WS8-30<br>DLC DL pro<br>FALC & PFD |
| <b>Software function</b>   |            |                       |   |   |   |   |   |   |
| Automatic RF lock          | ✓          | ✓                     | ✓   | ✓   | ✓   | ✓   | ✓   | ✓   |
| Remote optical lock        |            | ✓                     | ✓   | ✓   | ✓   | ✓   | ✓   | ✓   |
| Lock status                |            | ✓                     | ✓   | ✓   | ✓   | ✓   | ✓   | ✓   |
| Monitor beat FFT           |            |                       | ✓   | ✓   | ✓   | ✓   | ✓   | ✓   |
| Count beat frequency       |            |                       | ✓   | ✓   | ✓   | ✓   | ✓   | ✓   |
| Calculate comb tooth #     |            |                       |   | ✓   |   | ✓   |   | ✓   |
| Calculate laser frequency  |            |                       | ✓*  | ✓   | ✓*  | ✓   | ✓*  | ✓   |
| Frequency trace            |            |                       | ✓*  | ✓   | ✓*  | ✓   | ✓*  | ✓   |
| Automatic data acquisition |            |                       | ✓   | ✓   | ✓   | ✓   | ✓   | ✓   |
| Allan deviation            |            |                       | ✓   | ✓   | ✓   | ✓   | ✓   | ✓   |
| Remote lock cw-laser       |            |                       |   |   |   |   | ✓   | ✓   |

\* Comb Tooth # needs to be set manually

**One interface for all system configurations**



# Complete DFC Systems

Buy a stable, optical frequency

# Example scheme of complete DFC System

For strontium lattice clock experiment



- All from one single source
- Designed to work together
- Easy to use
- Controlled from a single GUI

Complete stabilized laser systems including the DFC CORE +, any desired wavelength extension, beat units, stabilization electronics, wavelength meters, counters, and lasers are now available from one source.

Any of TOPTICA's tunable diode lasers with a wavelength between 420 nm and 2000 nm can be locked to the DFC, lasers

with shorter wavelengths can be stabilized using the fundamental of their SHG unit. The complete laser system is controlled from a single GUI.

| Module   | Description  |
|--|--|
| Frequency Comb   | DFC CORE + Difference Frequency Comb, 4 offset-free outputs @ 1560 nm, > 10 mW, > 20 nm  |
| Wavelength extension*                                      | DFC IR Centered @ 1560 nm, bandwidth > 80 nm, typ. 100 nm  |
|  | DFC NIR Centered @ 780 nm, bandwidth > 35 nm, typ. 40 nm   |
|  | DFC DVIS** Wavelength range 420 (f <sub>rep</sub> = 80 MHz), 450 (f <sub>rep</sub> = 200 MHz) - 860 nm, bandwidth typ. 5 nm @ 698 nm, typ. 1 nm @ 420 nm |
|  | DFC SCNIR** Wavelength range 840 nm (f <sub>rep</sub> = 80 MHz), 860 nm (f <sub>rep</sub> = 200 MHz) - 980 nm, bandwidth > 50 nm, typ. 100 nm @ 935 nm   |
| DFC SCIR** Wavelength range 980 - 2000, bandwidth > 150 nm |  |
| Reference  | DFC RF Low-noise oven-controlled quartz, output: 800 MHz, input: 10 MHz  |
|  | DFC GPS GPS frequency reference, output: 10 MHz, stability: 1.3 · 10 <sup>-12</sup> @ 1s, 1 · 10 <sup>-13</sup> @ 40000 s                                |
| Beat units   | DFC BC Beam combiner for DFC and cw-laser, fiber coupled   |
|  | DFC BCF Fiber beam combiner for DFC and cw-laser, 980 nm, 1030 nm, 1300 nm, 1550 nm  |
|  | DFC MD Monochromatic detector unit, fiber coupled, use with DFC BC / DFC BCF   |
| Locking electronics  | FALC Fast analog 2-channel PID   |
|  | PFD Phase frequency detector, enables remote locking with FALC   |
|  | DLC EXT Housing and power supply for FALC and PFD  |
| Accessories  | DFC SCOPE Digital oscilloscope with spectrum analyzer (FFT), for convenient beat monitoring from software  |
|  | DFC COUNT 4 channel counter  |
|  | WS8-30 HighFinesse wavelength meter, for convenient determination of comb line number  |
| Rack integration   | MDFC Rack integration of any DFC component and complete comb systems (e.g. MDFC CORE +)  |

\* other extensions on request, \*\* tunable (patent protected, US 8284808B2), please inquire for more details

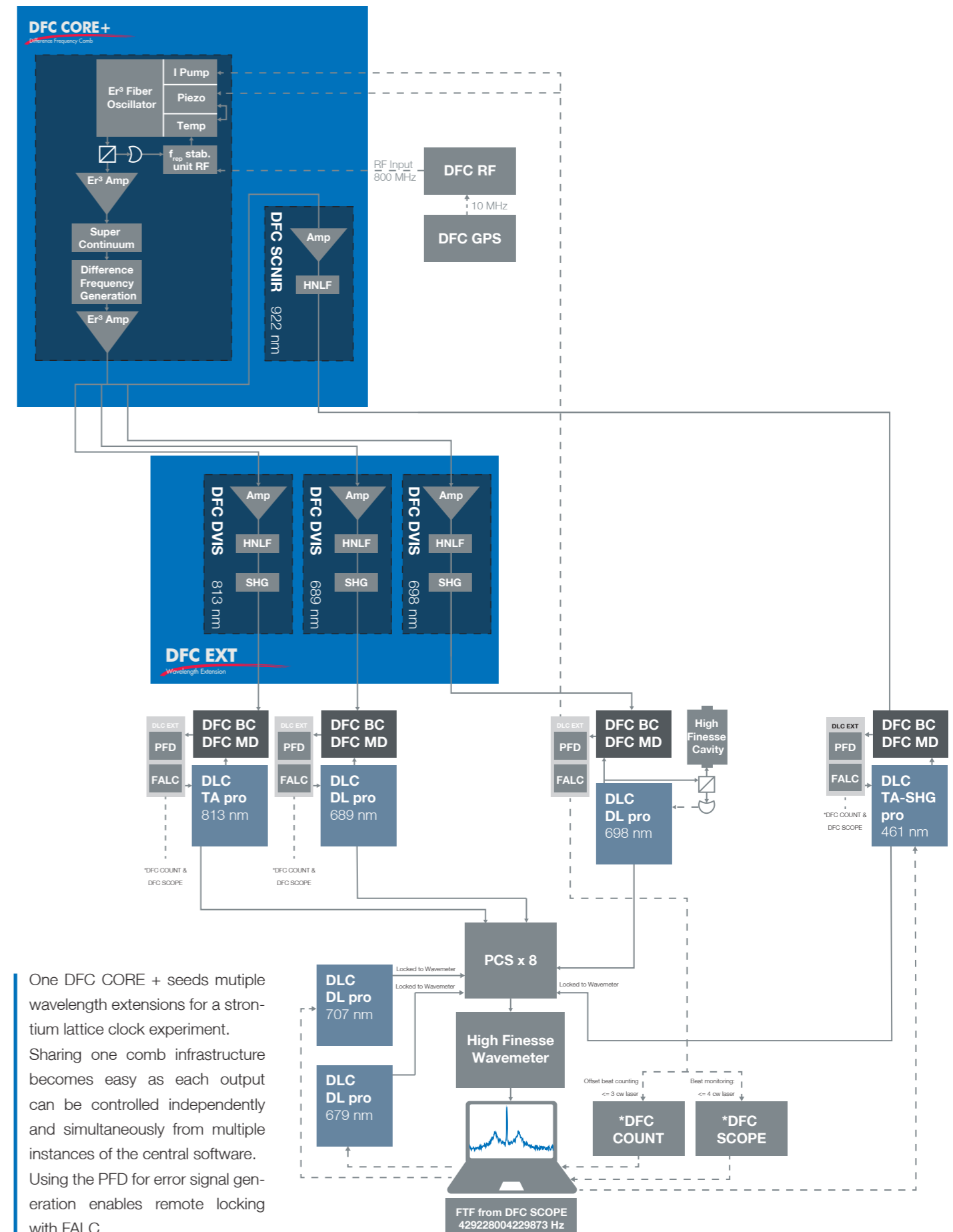

One DFC CORE + seeds multiple wavelength extensions for a strontium lattice clock experiment. Sharing one comb infrastructure becomes easy as each output can be controlled independently and simultaneously from multiple instances of the central software. Using the PFD for error signal generation enables remote locking with FALC.



# TOPTICA Worldwide



**Australia & New Zealand**  
**Lastek Pty. Ltd.**  
[www.lastek.com.au](http://www.lastek.com.au)

**France**  
**Opton Laser International**  
[www.optonlaser.com](http://www.optonlaser.com)

**India**  
**Simco Global Technology & Systems Ltd.**  
[www.simco-groups.com](http://www.simco-groups.com)

**Israel**  
**Lahat Technologies Ltd.**  
[www.lahat.com](http://www.lahat.com)

**Russia**  
**EuroLase Ltd.**  
[www.eurolase.ru](http://www.eurolase.ru)

**Singapore & Malaysia & Thailand**  
**Precision Technologies Pte Ltd**  
[www.pretech.com.sg](http://www.pretech.com.sg)

**South Korea**  
**JINSUNG INSTRUMENTS, INC.**  
[www.jinsunginst.com](http://www.jinsunginst.com)

**Taiwan**  
**Luxton Inc.**  
[www.luxton.com.tw](http://www.luxton.com.tw)

**United Kingdom & Ireland**  
**TOPTICA Photonics UK**  
[www.toptica.com](http://www.toptica.com)

**TOPTICA Photonics AG**  
Lochhamer Schlag 19  
D-82166 Graefelfing / Munich  
**Germany**  
Phone: +49 89 85837 0  
Fax: +49 89 85837 200  
[sales@toptica.com](mailto:sales@toptica.com)  
[www.toptica.com](http://www.toptica.com)

**TOPTICA Photonics Inc**  
5847 County Road 41  
Farmington, NY 14425  
**U.S.A. & Canada & Mexico**  
Phone: +1 585 657 6663  
Fax: +1 877 277 9897  
[sales@toptica-usa.com](mailto:sales@toptica-usa.com)  
[www.toptica.com](http://www.toptica.com)

**TOPTICA Photonics, K.K.**  
Asahi-seimei Bldg. 2F  
1-14-1 Fuchu-cho, Fuchu-shi  
Tokyo 183-0055  
**Japan**  
Phone: +81 42 306 9906  
Fax: +81 42 306 9907  
[sales@toptica-japan.com](mailto:sales@toptica-japan.com)  
[www.toptica.co.jp](http://www.toptica.co.jp)

**TOPTICA Photonics (China) Co., Ltd.**  
Room 1837, Bund Centre  
222 East YanAn Rd  
Huangpu District Shanghai, 200333  
**China**  
Phone: +86 21 619 335 09  
[toptica@toptica-china.com](mailto:toptica@toptica-china.com)  
[www.toptica-china.com](http://www.toptica-china.com)

